

Drenagem Rua 25 de Julho
 Trecho km 0+0,00 a 0+135,36
 ESCALA 1:200

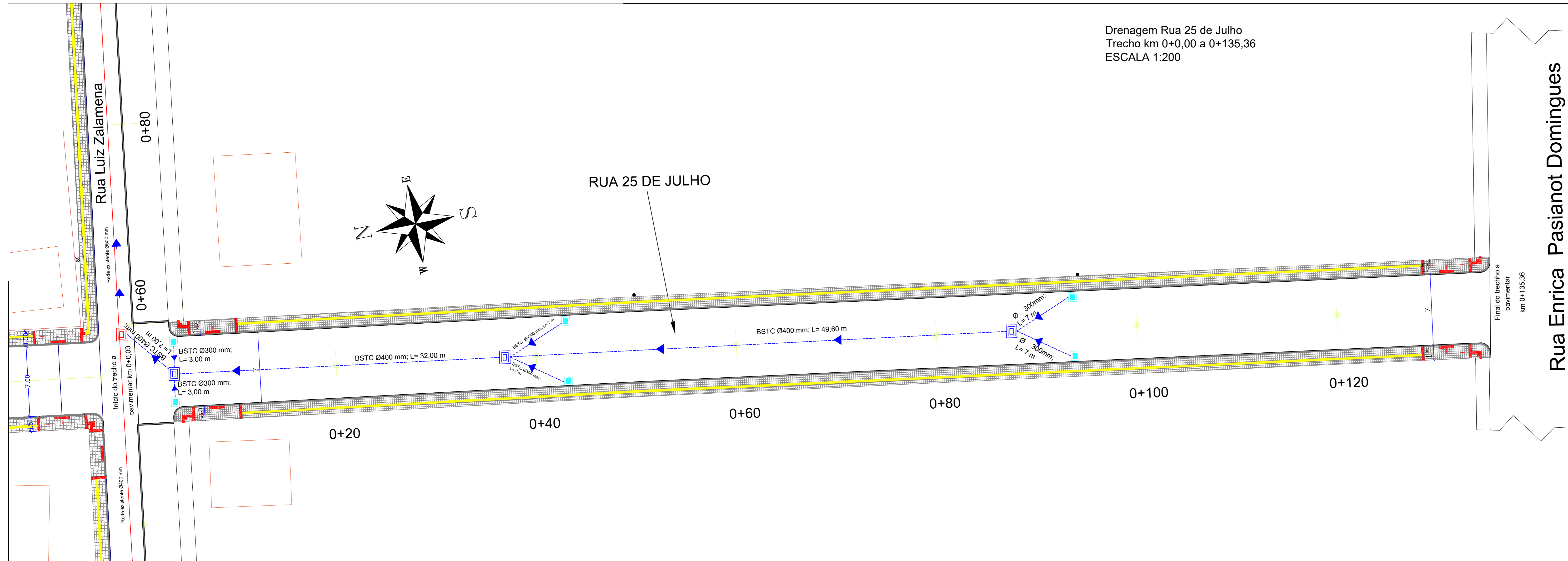

LEGENDA

- Bueiro existente, Ø indicado
- Bueiro a construir, Ø 400 mm
- Sentido do escoamento pluvial
- Caixa de ligação existente
- Caixa de ligação a construir
- Boca de lobo a construir

DETALHES DAS BOCAS DE LOBO

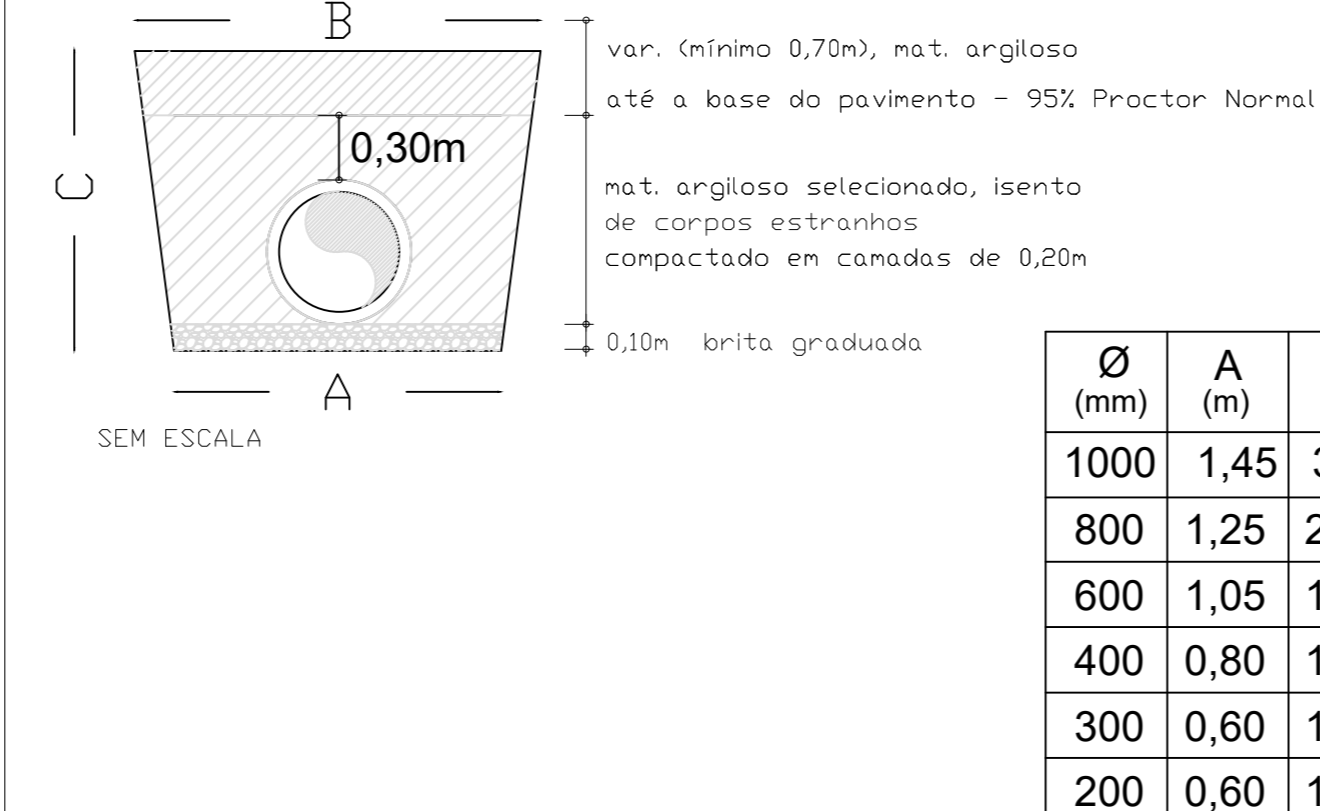
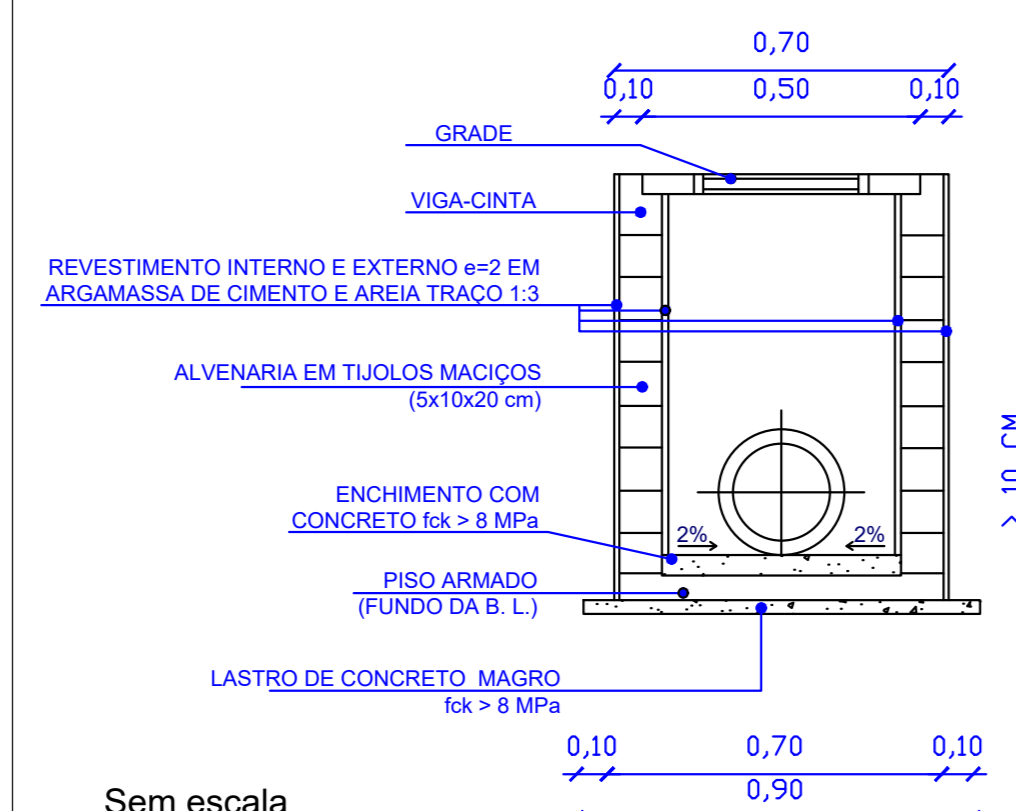
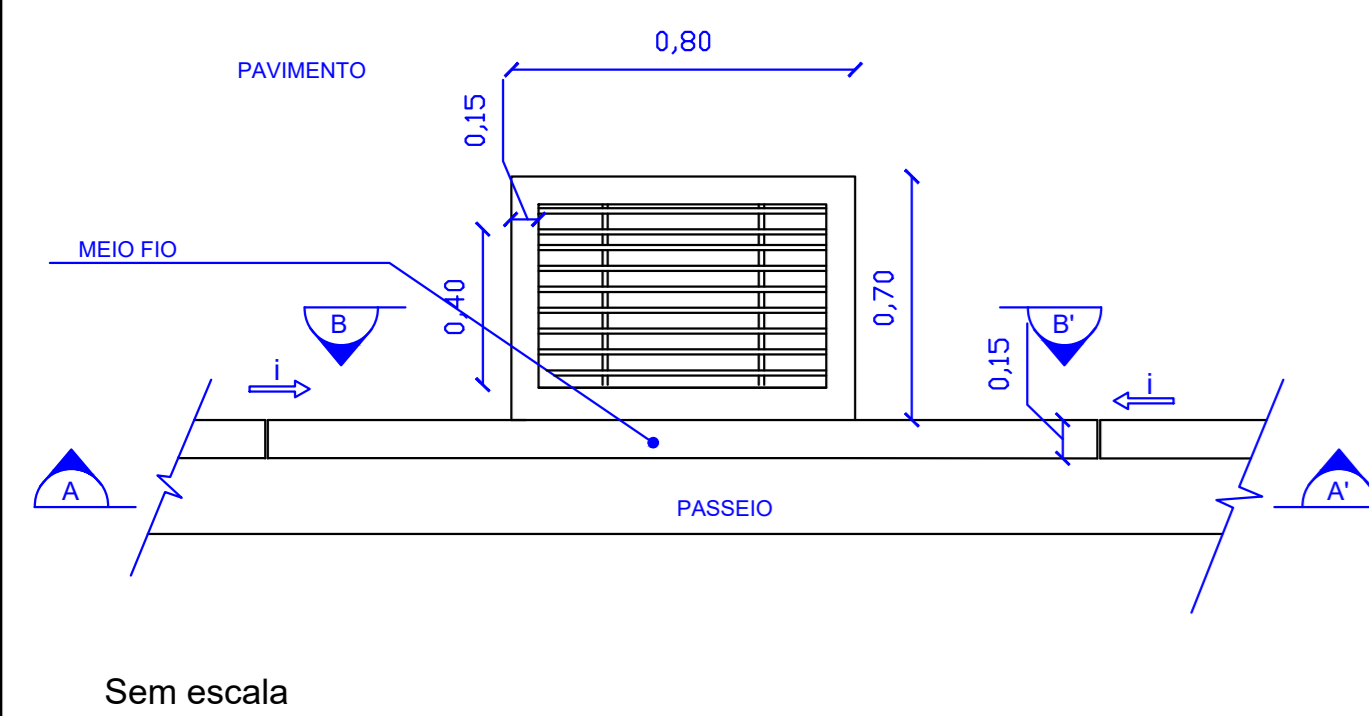

DETALHES DAS CAIXAS DE LIGAÇÃO

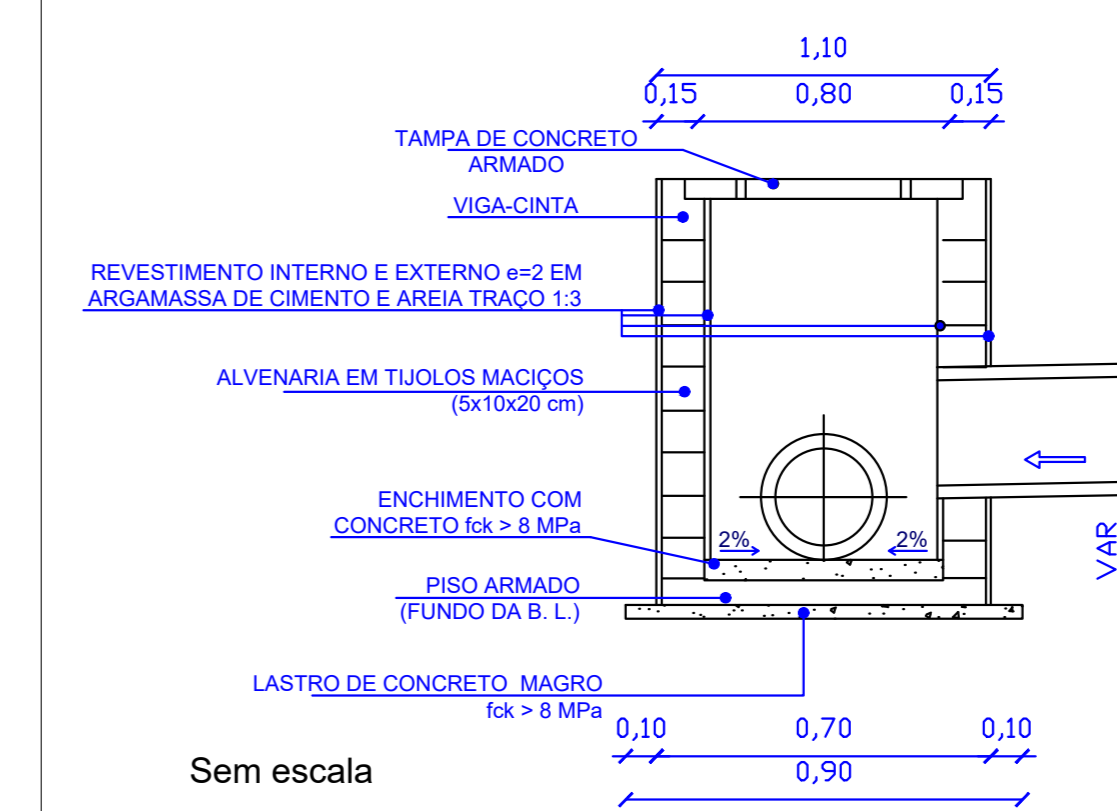
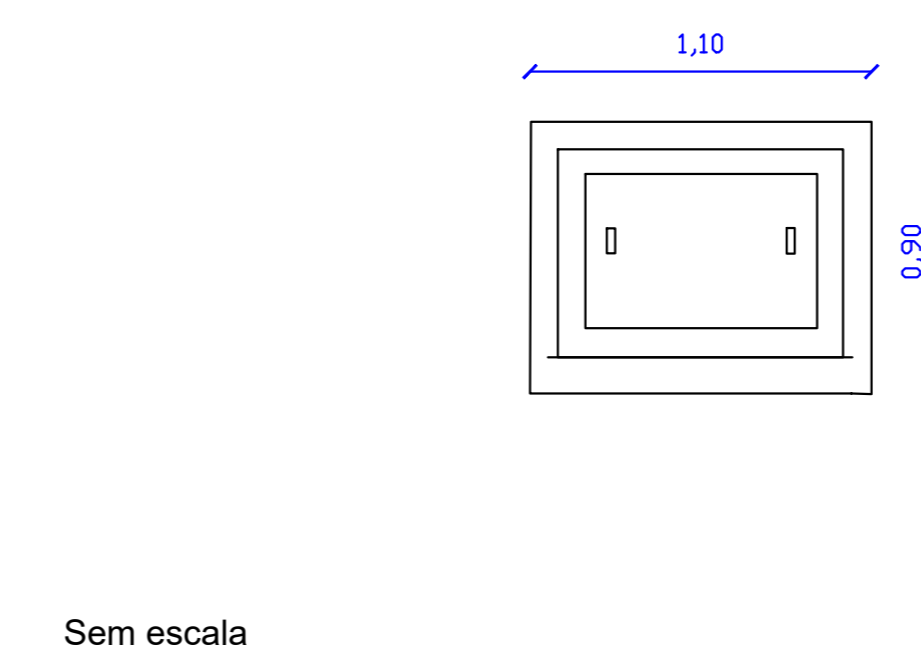

OBRA/LOCAL

PAVIMENTAÇÃO DE RUAS
 Rua 25 de Julho, trecho 0+00 a 0+135,36

PROPRIETÁRIO

Prefeitura Municipal de Cotiporá CNPJ: 90.898.487/0001-64

RESPONSÁVEL TÉCNICO

Eng. Civil Kátia Benedetti

CREA/RS 201849

DATA

Abril / 2017

DESENHO

Kátia / Cristiano

ESCALA

INDICADA

PROJETO DE PAVIMENTAÇÃO

ASSUNTO

DRENAGEM



FRANCHA

03